



Fan cooler SWK

Fan cooler for effective temperature reduction, for water connection

Application

SWK is a fan cooler for environments where cool indoor air is required. SWK is suitable for use in shops, warehouses and other environments where cooling is needed.

Comfort

SWK delivers comfortable cooling without compromising on sound level. Low sound level and adjustable fan speed provide optimum conditions for a pleasant indoor environment.

Operation and economy

The SWK fan cooler provides rapid and efficient cooling at low cost. SWK is an excellent choice when considering making use of free cooling. Smart design facilitates maintenance and makes installation easy.

Design

The SWK fan cooler is supplied in a white epoxy-coated steel plate finish, which makes it suitable for most environments where a low profile is required.

Product specifications

- Designed for cooling operation
- Hydrophilic-coated aluminium fins for better drainage.
- Insulated drip tray in stainless steel.
- 4 mm fin spacing minimises the risk of dust and dirt clogging up water coil.
- Supplied with air director with individually adjustable louvres that direct the air flow on one plane.
- Wall brackets included.
- Corrosion proof housing made of hot zinc-plate and powder enameled steel panels. Colour: RAL 9016, NCS S 0500-N (white). Housing without lacquer or in other colours available on request.

Technical specifications

Fan cooler SWK (IP44)

Type	Cooling output (total)* ¹ [kW]	Cooling output (sensible)* ¹ [kW]	Airflow [m ³ /h]	Airflow [m ³ /s]	Sound power* ² [dB(A)]	Sound pressure* ³ [dB(A)]	Air throw [m]	Water volume* ⁴ [l]	Voltage [V]	Amperage [A]	Weight [kg]
SWK12	5,9	5,1	2000	0,55	68	52	8	3,0	230V~	0,6	51
SWK22	10,3	8,9	3500	0,97	78	62	8	5,1	230V~	0,95	66

*¹) Applies at water temperature +6/12 °C, air temperature in +25 °C, relative humidity 50 %.

*²) Sound power (L_{WA}).

*³) Sound pressure (L_{pA}). Conditions: Distance to the unit 5 metres.

*⁴) Water volume inside water coil.

Intended for water temperatures from 0 °C up to +150 °C and 16 bar.
Max. surrounding temperature +40 °C.

Dimensions

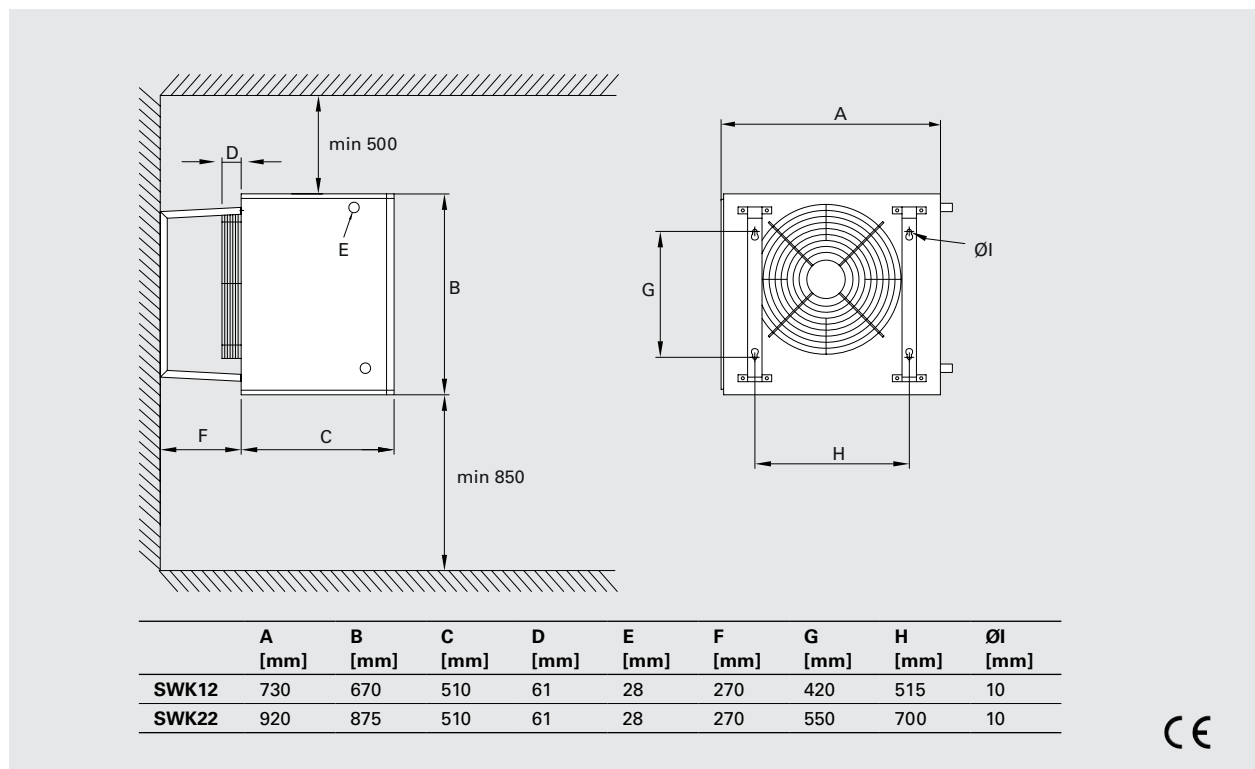

Fan cooler SWK

Mounting and connection

Mounting

The fan cooler is for wall mounting with mounting brackets provided. For minimum distance, see dimension diagrams.

The fan cooler is supplied with tube connections on the left-hand side. The water coil has copper tubes with smooth pipe connections, for press-fitting or clamp ring coupling. The condensate drain has a G1/2" connection.

Connection

The fan motor is connected to a detached terminal box, which is mounted on a wall next to the unit.

Accessories

SDB, extra air director

To direct the air stream sideways. On delivery, the fan cooler is equipped with an air director for vertical direction of the air stream.

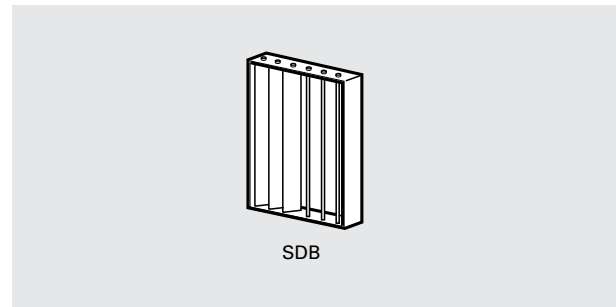

Type	Description	SWK12	SWK22	HxWxD [mm]
SDB12	Extra air director	•		675X654X82
SDB22	Extra air director		•	880X784X82

Control

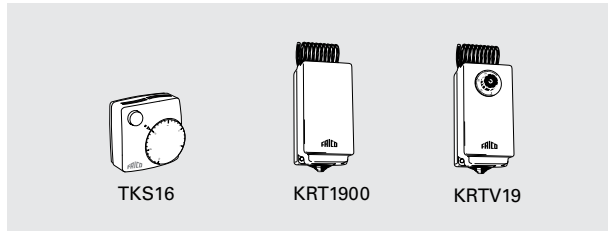

TKS16, thermostat
 Processor controlled thermostat with visible dials and 1-pole main switch. Setting range +5 – +30 °C. Alternating contact for heating or cooling. Connection voltage: 230 V. Max. breaking current: 16 A. IP30.

KRT1900/KRTV19, capillary tube thermostats
 Capillary tube thermostat with concealed (KRT1900) or visible knob (KRTV19). Setting range 0 – +40 °C. Max. breaking current: 16/10 A (230/400V). IP55 (KRT1900) or IP44 (KRTV19).

Water control

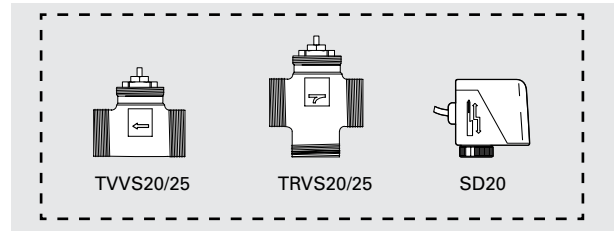

TVVS20/25, valves + SD20, actuator*
 TVVS20/25, 2-way regulation valve and SD20, actuator on/off provides a basic form of water regulation, without the possibility of adjusting or shutting the water flow off, e.g. when making maintenance. A suitable thermostat is chosen to regulate TVVS20/25 and SD20. DN20/25.

TRVS20/25, 3-way control valve
 If a 3-way valve is preferred, TRVS20/25 can be used instead of TVVS20/25.

Type	Description	HxWxD [mm]
TKS16	Electronic thermostat, knob, 1-pole switch, IP30	80x80x39
KRT1900	Capillary tube thermostat, IP55	165x57x60
KRTV19	Capillary tube thermostat with knob, IP44	165x57x60
TVVS20	2-way valve DN20	
TVVS25	2-way valve DN25	
TRVS20	3-way valve DN20	
TRVS25	3-way valve DN25	
SD20	Actuator on/off 230V	

Output charts water

Supply / return water temperature 6/12 °C, relative humidity 50 %											
Type	Airflow [m³/h]	Air temp. in. = +25 °C					Air temp. in. = +30 °C				
		Cooling output (total) [kW]	Cooling output (sensible) [kW]	Air temp. out [°C]	Water flow [l/s]	Pressure drop [kPa]	Cooling output (total) [kW]	Cooling output (sensible) [kW]	Air temp. out [°C]	Water flow [l/s]	Pressure drop [kPa]
SWK12	2000	5,9	5,1	17,1	0,23	4,7	11,0	6,9	19,1	0,44	14,3
SWK22	3500	10,3	8,9	17,1	0,41	5,1	19,2	12,1	19,1	0,76	15,4

Fan cooler SWK

Wiring diagrams

Internal wiring diagram

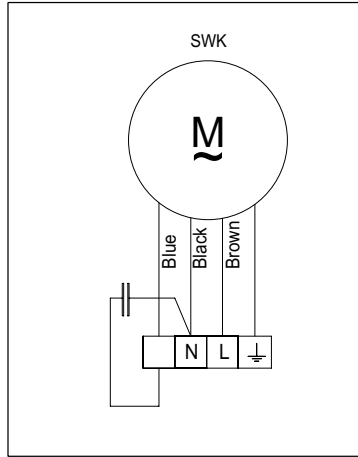

Control by thermostat only

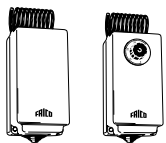
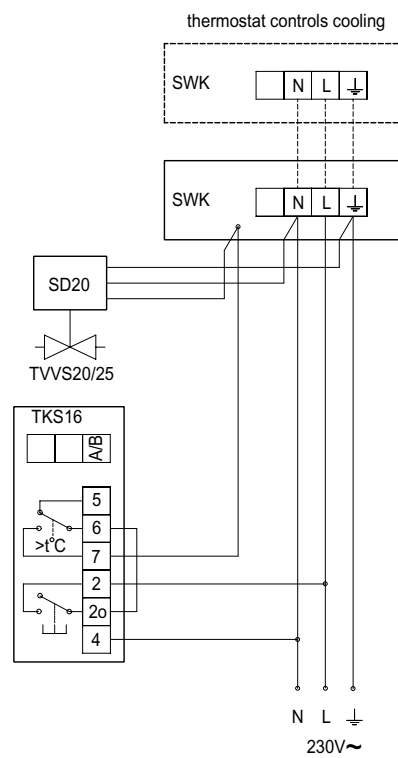
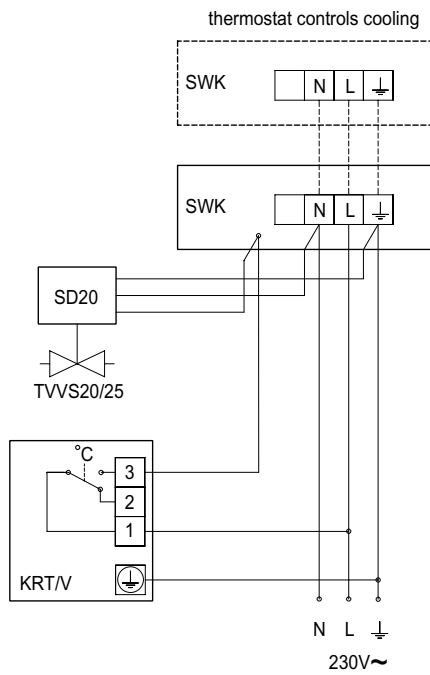

KRT1900/KRTV19,
capillary tube thermostat



TKS16,
electronic thermostat